

*intecna*

innovazione miglioramento e tecnologie  
per l'azienda

**INTECNA scarl**

*IL NOSTRO IMPEGNO PER MIGLIORARE LA TECNOLOGIA  
GESTIONALE DELLA VOSTRA AZIENDA*



*intecna*

innovazione miglioramento e tecnologie  
per l'azienda

**Società di consulenza  
e progettazione aziendale**

dal 1993 al servizio di imprese dinamiche,  
in linea con l'evoluzione del mercato

INTECNA scarl - Viale Fulvio Testi 11, 20092 Cinisello Balsamo (MI) - Tel: 02/61866321 - Fax: 02/61866710 - www.intecna.it



[www.intecna.it](http://www.intecna.it)

*intecna*

innovazione miglioramento e tecnologie  
per l'azienda

**INTECNA scarl**

## *SAP Business One Integration*



**B1 Integration for SAP Netweaver (B1iSN)**

*intecna*

innovazione miglioramento e tecnologie  
per l'azienda

**INTECNA scarl**

*Tool SAP per integrare B1 con il mondo esterno!*



*La soluzione al problema dell'interazione tra sede e periferia*

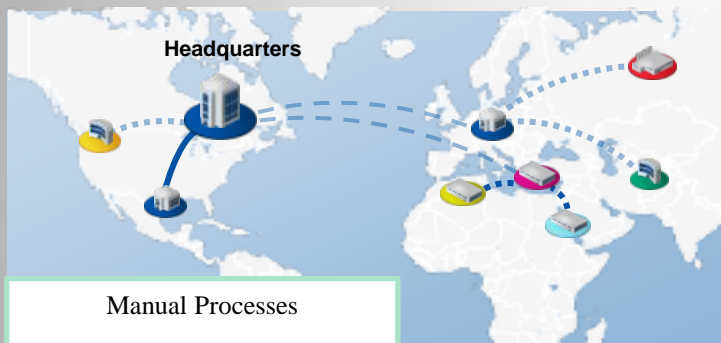

Manual Processes

**Integrazione tra  
periferia e sede  
centrale con B1iSN**



Fully integrated with B1iSN

*Progettato inizialmente per integrare B1 ↔ R3.....*

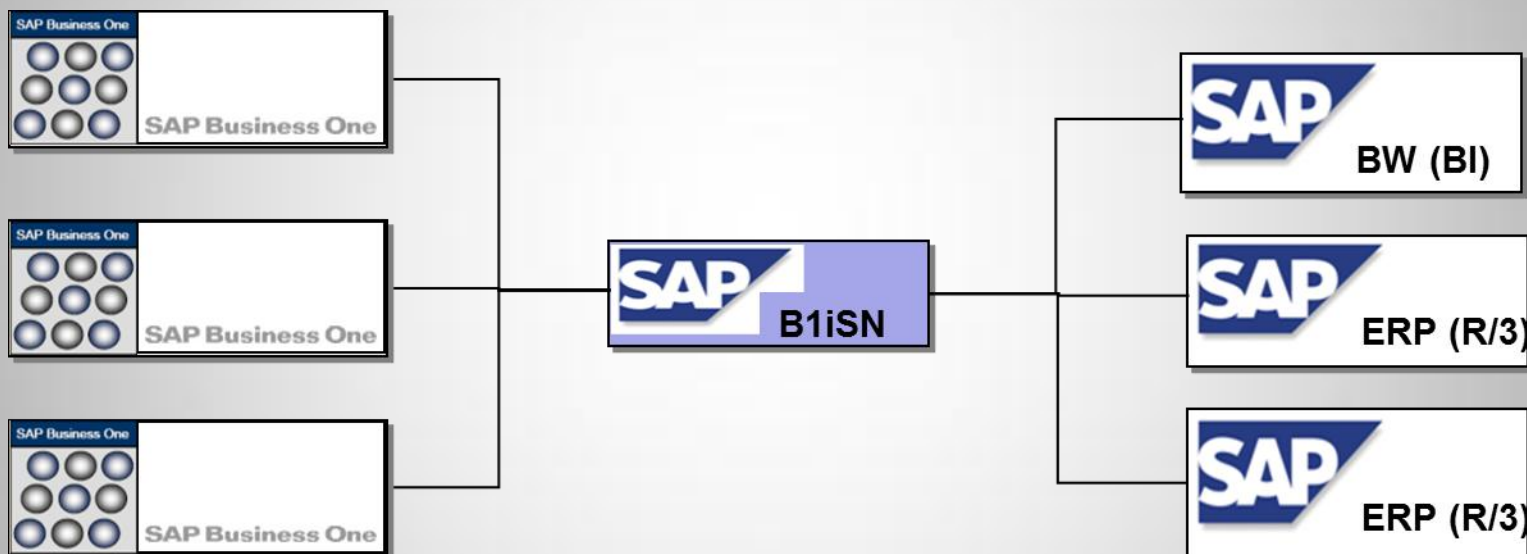

*.....è in grado di integrare sistemi diversi*

**Grazie ai numerosi standard supportati, B1iSN 2007  
fornisce molti tipi di connessioni ed è in grado di  
integrare sistemi diversi, anche non-SAP!**

- SAP Business One (DI, SQL)
- SAP ERP (RFC / ALE/XI-PI)
- SAP NetWeaver BW (RFC / SOAP)
- Database systems (SQL)
- HTTP any
- File (CSV, Offset)
- Web Services (In/Out, Sync/Async)

***Per ogni tipo di  
connessione più sistemi  
possono essere settati  
("molti a molti")***

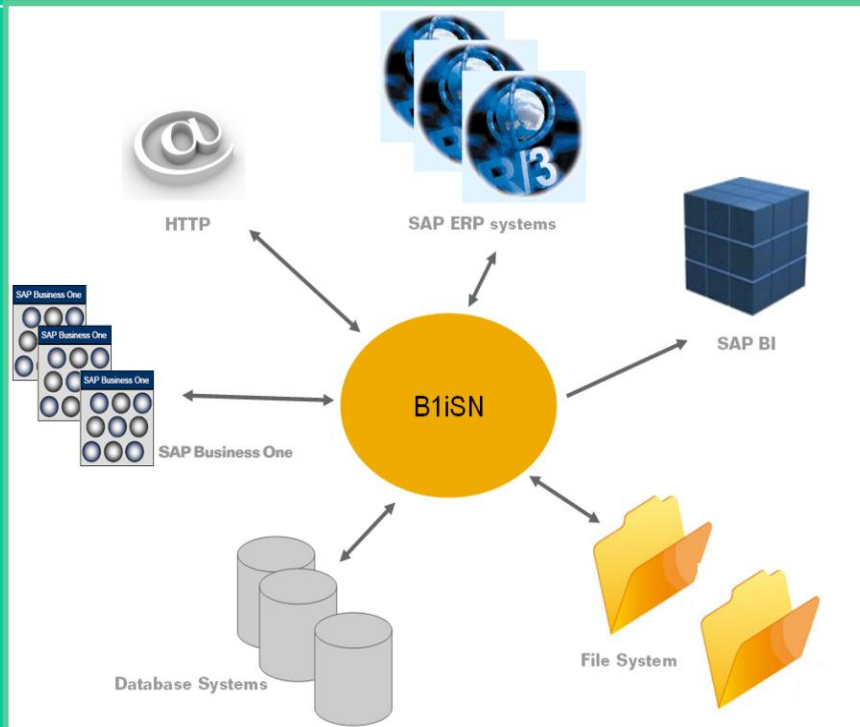

## Tipico scenario di Integrazione e vantaggi

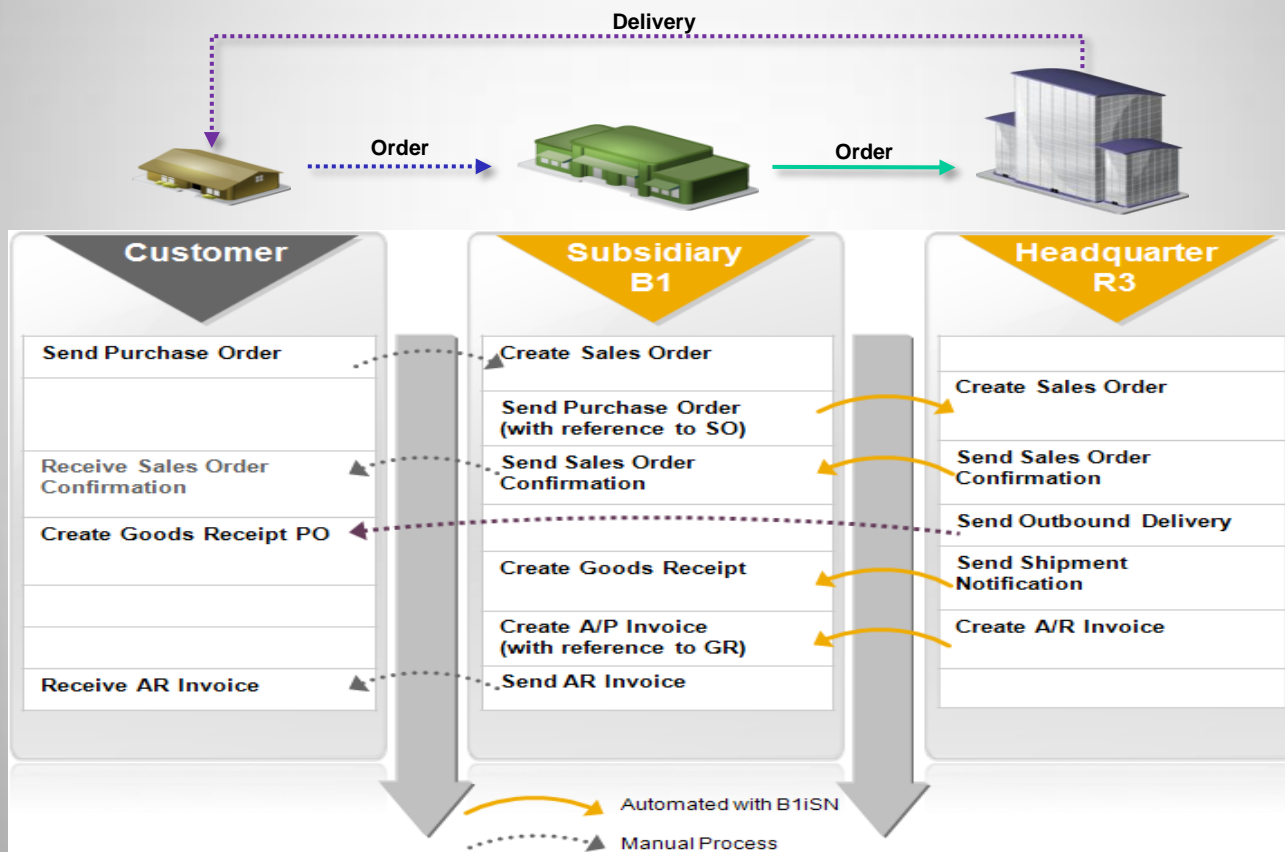

## *I vantaggi di B1iSN*

<b>L'architettura(B1iSN) che integra i Processi Aziendali, centrali(R/3) e periferici con(SAP Busines One) (B1iSN), consente di usufruire di notevoli vantaggi.</b>	<b>Tipologia di Vantaggi</b>
	<b>Generali</b> $\geq$
	<b>Organizzativi</b> $\geq$
	<b>Operativi</b> $\geq$
	<b>Economici</b> $\geq$

## *Vantaggi Generali*

Sap Business One si adatta meglio alla dimensione medio piccola delle sedi periferiche e risulta più conveniente di un Roll-Out di Sap R/3.

Consente alla società periferica una autonomia amministrativa.

In caso di interruzione del rapporto, con HQ, garantisce continuità gestionale per la filiale.

*intecna*

innovazione miglioramento e tecnologie  
per l'azienda

**INTECNA scarl**

## *Vantaggi Organizzativi*

Integrazione coerente nel processo aziendale centrale della periferia, quasi sempre lasciata a se stessa.

Integrazione real-time con il centro dei processi di acquisto Intercompany

Integrazione nel consolidato centrale delle realtà periferiche

The logo for Intecna, featuring the word "intecna" in a blue, cursive font with a red and orange swoosh underneath.

innovazione miglioramento e tecnologie  
per l'azienda

**INTECNA scarl**

## *Vantaggi Operativi*

Più semplice da usare di R/3 per gli utenti finali

Garantisce un uso immediato anche per utenti poco “informatici”

Omogeneità di gestione aziendale centrale e periferica

*intecna*

innovazione miglioramento e tecnologie  
per l'azienda

**INTECNA scarl**

## *Vantaggi Economici*

Costi globali di progetto contenuti e costi per singola società estremamente ridotti

Costi marginali per società aggiuntive estremamente ridotti

Implementazione e Manutenzione a bassi costi

## Logica di Customizing in B1iSN

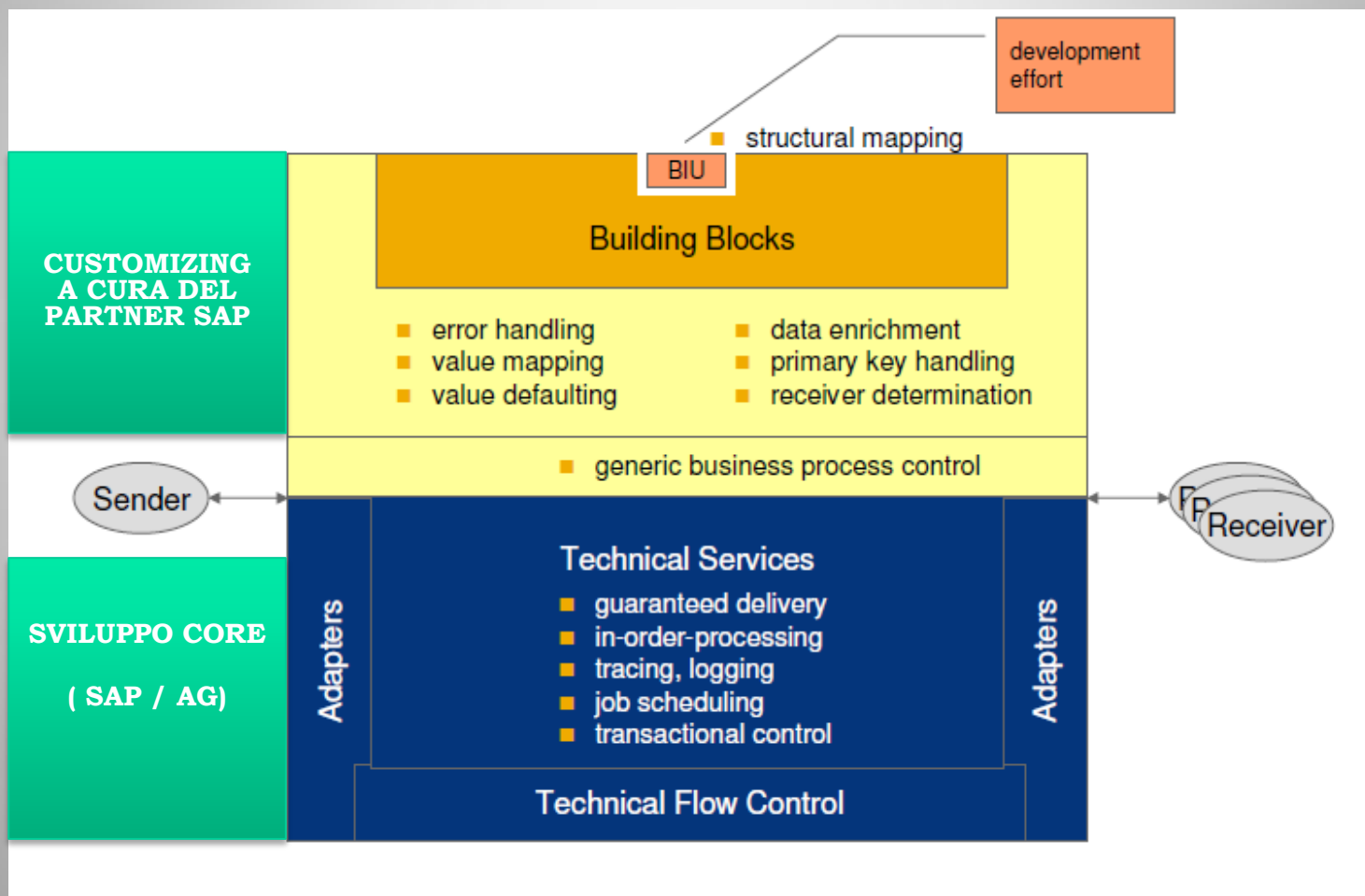

## Logica di Funzionamento

Il core di B1iSN gestisce una logica a «piccoli passi» : IPO STEPS

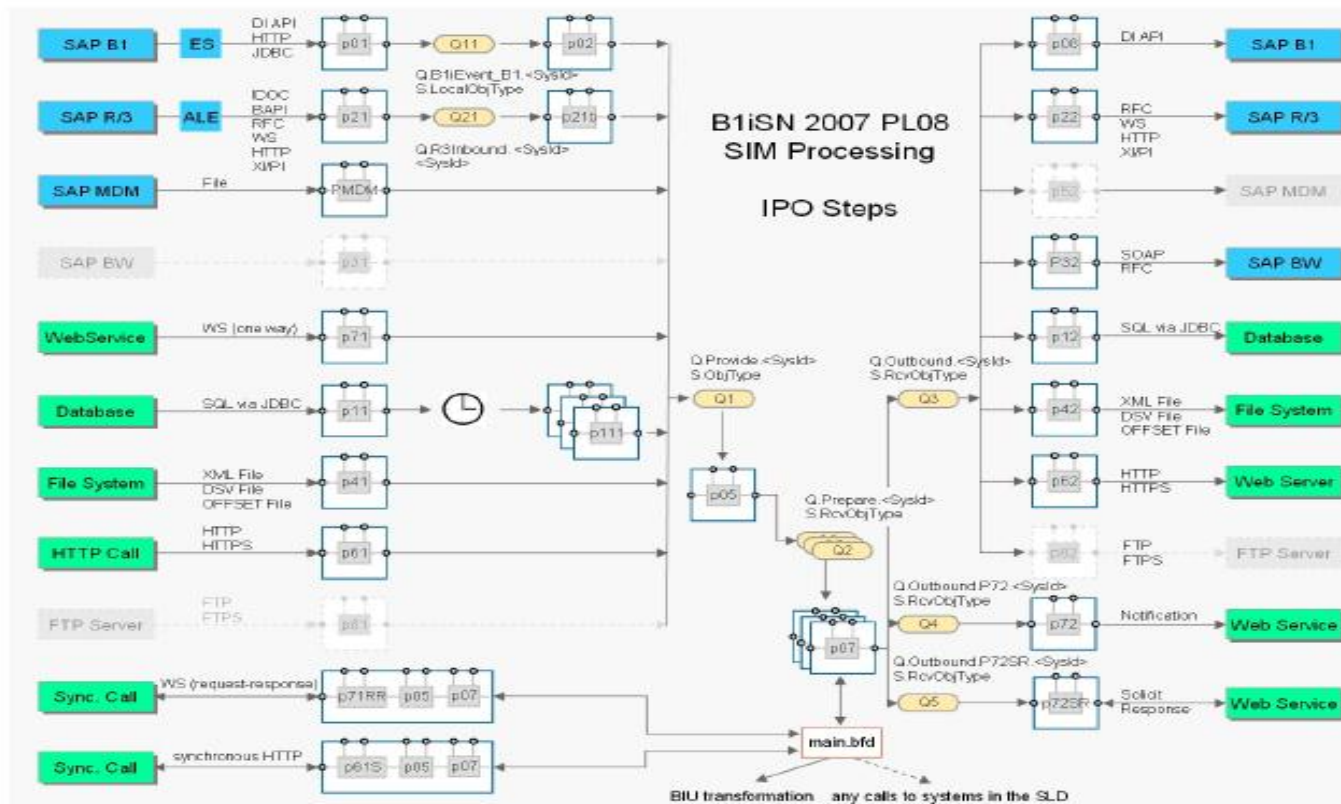

# intecna

innovazione miglioramento e tecnologie  
per l'azienda

# INTECNA scarl

BiISN Overview

*Sviluppato in Java*

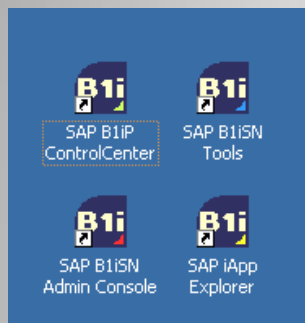

Connect to localhost

The server localhost at sap.com/B1i/cellerator requires a username and password.

Warning: This server is requesting that your username and password be sent in an insecure manner (basic authentication without a secure connection).

User name:

Password:

Remember my password

OK Cancel

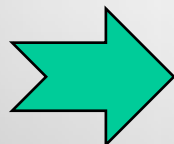

**B1iSN è un applicativo sviluppato in Java,  
quindi tutte le funzioni sono accessibili mediante i  
più diffusi browsers (es.: MS Internet Explorer) con  
accesso protetto da utenza e password  
predefinibile**



## *Attività operative semplici e guidate*

**Con BliSN, una volta progettati e customizzati gli scenari di integrazione, le attività operative sono molto semplici guidate.**

- Definizione del Landscape e tipi di sistemi interconnessi
- Definizione dei flussi di dati scambiati per tipo
- Monitoraggio quotidiano dei flussi di dati

*Interfaccia utente completa e facile da usare*

The screenshot displays the SAP Business One 2007 Integration Application Explorer interface. The main content area shows the configuration for system **T06CLNT690**. The interface is divided into several sections:

- General Information:** Type: ECC6.0, Name: T06CLNT690, ID: 0010000105.
- Connectivity List (Active):** A section containing a **Test Connection** button.
- RFCA:** A table of connection parameters for RFC connections.

Parameter	Value
applicationServer	ITPRES01
client	690
user	ZUCCHI_J
password	.....
language	EN
systemNumber	61
maxConnections	2
gatewayHost	ITPRES01
gatewayServiceNumber	sapgw61
senderPartner	R100

Red circles highlight the **Edit**, **Delete**, and **Copy** buttons in the top right, and the **Test Connection** button in the connectivity list section.

**Schema intuitivo dei sistemi coinvolti con i rispettivi parametri di connessione e possibilità di test delle connessioni definite**

## Anagrafiche e Documenti

SAP B1SN Admin Console

SAP Business One 2007 integration platform  
SAP Business One 2007 integration for SAP NetWeaver

Language

Landscapes Initialization Business Processes Data Management Monitoring Tools

- Intercompany Purchasing
- Management Reporting
- Master Data**

Info Modify Delete (De)Activate

Filter: BizPackage Sender System Receiver System Display

BizPackage Instance	Sender System(s)	Receiver System(s)	Active Status	Last Run Time	Processing Status	Process Type
C Business Partners	D06CLNT690	AUSTRIA	■	--	--	↻
C Customers (TEST)	T06CLNT690	<Multiple>	■	--	--	↻
C Materials (DEVEL)	D06CLNT690	AUSTRIA	■	--	--	↻
C Materials (TEST)	T06CLNT690	AUSTRIA	■	--	--	↻

ANAGRAFICHE

SAP B1SN Admin Console

SAP Business One 2007 integration platform  
SAP Business One 2007 integration for SAP NetWeaver

Language

Landscapes Initialization Business Processes Data Management Monitoring Tools

- Intercompany Purchasing**
- Management Reporting
- Master Data

Info Modify Delete (De)Activate

Filter: BizPackage Sender System Receiver System Display

BizPackage Instance	Sender System(s)	Receiver System(s)	Active Status	Last Run Time	Processing Status	Process Type
C Intercompany Artemide (SVILUPPO)	AUSTRIA	D06CLNT690	■	--	--	↻
C Intercompany Artemide (TEST)	<Multiple>	T06CLNT690	■	--	--	↻

DOCUMENTI

## Definizione flussi dati tra «Send» e «Receiver»

La metodologia per la definizione del flusso dei dati tra il sottosistema denominato «Send» e quello denominato «Receiver», è articolata in 5 passi operativi per ciascun Sistema configurato

### 1/5 - Setup Biz-Package

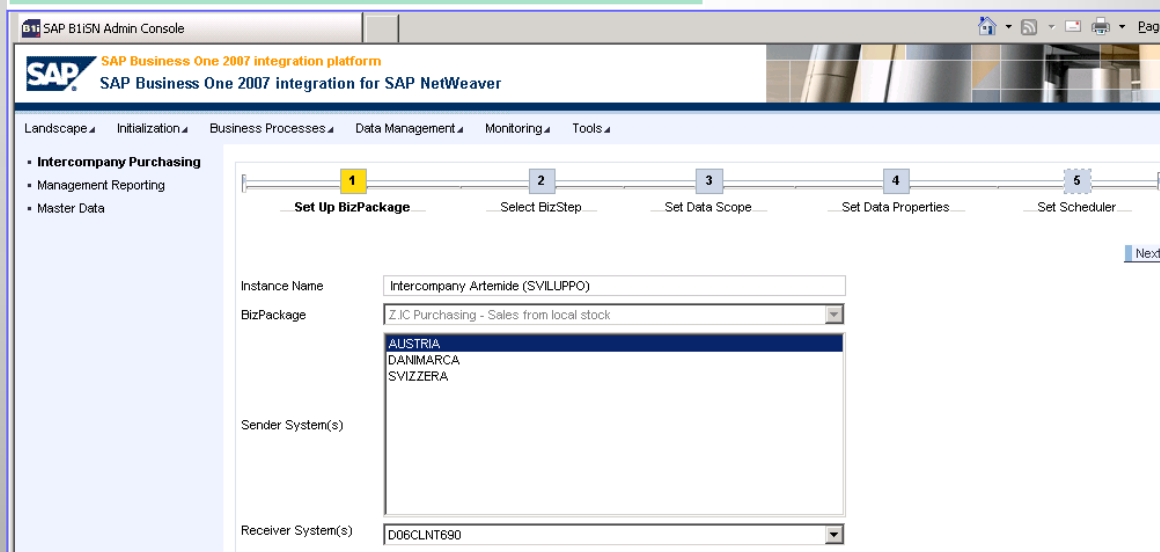

The screenshot displays the SAP B1ISN Admin Console interface. The main title is "SAP Business One 2007 integration platform" and "SAP Business One 2007 integration for SAP NetWeaver". The navigation menu includes Landscape, Initialization, Business Processes, Data Management, Monitoring, and Tools. The left sidebar shows a tree view with "Intercompany Purchasing" selected, containing "Management Reporting" and "Master Data". The main content area shows a progress bar with five steps: 1. Set Up BizPackage (highlighted), 2. Select BizStep, 3. Set Data Scope, 4. Set Data Properties, and 5. Set Scheduler. Below the progress bar, the "Set Up BizPackage" form is visible, with the following fields:

- Instance Name: Intercompany Artemide (SVILUPPO)
- BizPackage: Z.IC Purchasing - Sales from local stock
- Sender System(s): AUSTRIA, DANIMARCA, SVIZZERA
- Receiver System(s): D06CLNT690

A "Next" button is located at the bottom right of the form.

## Definizione flussi dati tra «Send» e «Receiver»

### 2/5 - Select Biz-Step

SAP B1SN Admin Console

SAP Business One 2007 integration platform  
SAP Business One 2007 integration for SAP NetWeaver

Navigation: Landscape | Initialization | Business Processes | Data Management | Monitoring | Tools

Left Menu:

- Intercompany Purchasing
- Management Reporting
- Master Data

Progress Bar:

- 1: Set Up BizPackage
- 2: **Select BizStep**
- 3: Set Data Scope
- 4: Set Data Properties
- 5: Set Scheduler

Buttons: Back | Next

Instance Name	BizPackage	Sender System(s)	Receiver System(s)
Intercompany Artemide (SVILUPPO)	Z.IC Purchasing - Sales from local stock	AUSTRIA	D06CLNT690

Options (circled in red):

- Intercompany Order
- Order Confirmation
- Shipping Notification without Inventory Posting
- Invoice

## Definizione flussi dati tra «Send» e «Receiver»

### 3/5 – Set Data Scope

SAP B1ISN Admin Console

SAP Business One 2007 integration platform  
SAP Business One 2007 integration for SAP NetWeaver

Landscapes Initialization Business Processes Data Management Monitoring Tools

- Intercompany Purchasing
- Management Reporting
- Master Data

1 2 3 4 5

...Set Up BizPackage... ...Select BizStep... **Set Data Scope** ...Set Data Properties... ...Set Scheduler...

Back Next

Instance Name	BizPackage	Sender System(s)	Receiver System(s)
Intercompany Artemide (SVILUPPO)	Z.IC Purchasing - Sales from local stock	AUSTRIA	D06CLNT690

BizStep	Sender System	Receiver System	Filter Criteria	Operand	Filter From	Filter To
Intercompany Order	AUSTRIA	D06CLNT690	Vendor Number			
Intercompany Order	AUSTRIA	D06CLNT690	Valid Vendor	equal to	TRUE	
Order Confirmation	D06CLNT690	AUSTRIA	Customer Number			
Shipping Notification with	D06CLNT690	AUSTRIA	Subsidiaries Custom			
Shipping Notification with	D06CLNT690	AUSTRIA	POType			
Invoice	D06CLNT690	AUSTRIA	Subsidiaries Custom			

## Definizione flussi dati tra «Send» e «Receiver»

### 4/5 – Set Data Properties

The screenshot shows the SAP B1iSN Admin Console interface. The main navigation bar includes Landscape, Initialization, Business Processes, Data Management, Monitoring, and Tools. The left sidebar lists 'Intercompany Purchasing', 'Management Reporting', and 'Master Data'. The main content area displays a workflow with five steps: 1. Set Up BizPackage, 2. Select BizStep, 3. Set Data Scope, 4. Set Data Properties (highlighted in yellow), and 5. Set Scheduler. Below the workflow, a summary table shows the instance name 'Intercompany Artemide (SVILUPPO)', BizPackage 'Z.IC Purchasing - Sales from local stock', Sender System(s) 'AUSTRIA', and Receiver System(s) 'D06CLNT690'. A yellow hand-drawn box highlights a detailed table of data properties for the selected BizStep.

BizStep	Sender System	Receiver System	Property	
Intercompany Order	AUSTRIA	D06CLNT690	IC Sales Organization	<input type="text"/>
Intercompany Order	AUSTRIA	D06CLNT690	IC Distribution Channel	02
Intercompany Order	AUSTRIA	D06CLNT690	IC Division	<input type="text"/>
Intercompany Order	AUSTRIA	D06CLNT690	Partner Role	WE
Intercompany Order	AUSTRIA	D06CLNT690	Order Type	Z005
Intercompany Order	AUSTRIA	D06CLNT690	Text ID	Z001
Order Confirmation	D06CLNT690	AUSTRIA	Text ID	<input type="text"/>

## Definizione flussi dati tra «Send» e «Receiver»

### 5/5 – Set Scheduler

The screenshot shows the SAP Business One 2007 integration platform interface. The top navigation bar includes 'Landscape', 'Initialization', 'Business Processes', 'Data Management', 'Monitoring', and 'Tools'. The left sidebar lists 'Intercompany Purchasing', 'Management Reporting', and 'Master Data'. The main content area displays a 5-step process flow: 1. Set Up BizPackage, 2. Select BizStep, 3. Set Data Scope, 4. Set Data Properties, and 5. Set Scheduler. The 'Set Scheduler' step is currently active. Below the process flow is a summary table with the following data:

Instance Name	BizPackage	Sender System(s)	Receiver System(s)
Intercompany Artemide (SVILUPPO)	Z.IC Purchasing - Sales from local stock	AUSTRIA	D06CLNT690

Below the summary table is a detailed table for the 'Set Scheduler' step, which is highlighted with a yellow border. This table lists the BizStep, Sender System, Receiver System, and Property for each data flow:

BizStep	Sender System	Receiver System	Property
Intercompany Order	AUSTRIA	D06CLNT690	IC Sales Organization
Intercompany Order	AUSTRIA	D06CLNT690	IC Distribution Channel
Intercompany Order	AUSTRIA	D06CLNT690	IC Division
Intercompany Order	AUSTRIA	D06CLNT690	Partner Role
Intercompany Order	AUSTRIA	D06CLNT690	Order Type
Intercompany Order	AUSTRIA	D06CLNT690	Text ID
Order Confirmation	D06CLNT690	AUSTRIA	Text ID

## Monitoraggio dei flussi di B1iSN

Il transito di ogni messaggio viene monitorato puntualmente.

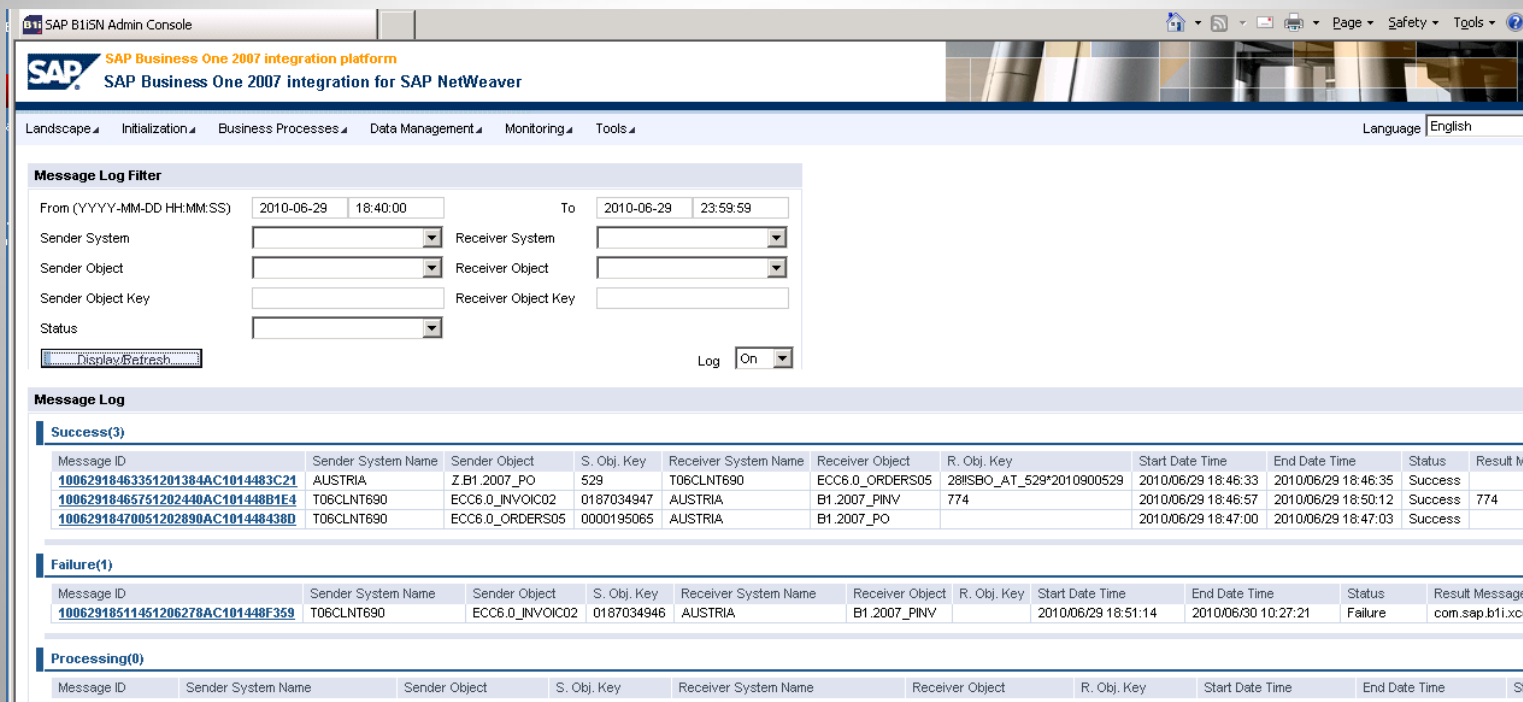

**Message Log Filter**

From (YYYY-MM-DD HH:MM:SS) 2010-06-29 18:40:00 To 2010-06-29 23:59:59

Sender System [ ] Receiver System [ ]

Sender Object [ ] Receiver Object [ ]

Sender Object Key [ ] Receiver Object Key [ ]

Status [ ]

Display/Refresh [ ] Log [ On ]

**Message Log**

**Success(3)**

Message ID	Sender System Name	Sender Object	S. Obj. Key	Receiver System Name	Receiver Object	R. Obj. Key	Start Date Time	End Date Time	Status	Result Message
10062918463351201384AC1014483C21	AUSTRIA	Z.B1_2007_PO	529	T06CLNT690	ECC6.0_ORDERS05	28ISBO_AT_529*2010900529	2010/06/29 18:46:33	2010/06/29 18:46:35	Success	
10062918465751202440AC101448B1E4	T06CLNT690	ECC6.0_INVOIC02	0187034947	AUSTRIA	B1_2007_PINV	774	2010/06/29 18:46:57	2010/06/29 18:50:12	Success	774
10062918470051202890AC101448438D	T06CLNT690	ECC6.0_ORDERS05	0000195065	AUSTRIA	B1_2007_PO		2010/06/29 18:47:00	2010/06/29 18:47:03	Success	

**Failure(1)**

Message ID	Sender System Name	Sender Object	S. Obj. Key	Receiver System Name	Receiver Object	R. Obj. Key	Start Date Time	End Date Time	Status	Result Message
10062918511451206278AC101448F359	T06CLNT690	ECC6.0_INVOIC02	0187034946	AUSTRIA	B1_2007_PINV		2010/06/29 18:51:14	2010/06/30 10:27:21	Failure	com.sap.b1i.xc

**Processing(0)**

Message ID	Sender System Name	Sender Object	S. Obj. Key	Receiver System Name	Receiver Object	R. Obj. Key	Start Date Time	End Date Time	Status	Result Message
------------	--------------------	---------------	-------------	----------------------	-----------------	-------------	-----------------	---------------	--------	----------------

## Individuazione del contenuto di ciascun messaggio

### Facilità di individuazione dei contenuti di ciascun messaggio

- **Stato messaggio:** Success, Failure, Processing, Filtered
- **Sender system name e Receiver System Name** (R/3, B1, ecc.)
- **Sender Object e Receiver Object** (Material, Orders, ecc.)
- **Sender Object Key e Receiver Object Key** (codice anagrafica o id documento) per una rapida ricerca.
- **Start Date Time e End Date Time**

#### Message Log

##### Success(11)

Message ID	Sender System Name	Sender Object	S. Obj. Key	Receiver System Name	Receiver Object	R. Obj. Key	Start Date Time	End Date Time
<a href="#">10062918102063872463AC1014486FDB</a>	AUSTRIA	Z.B1.2007_PO	527	T06CLNT690	ECC6.0_ORDERS05	28!SBO_AT_527*2010900527	2010/06/29 18:10:20	2010/06/29 18:10
<a href="#">10062918105763873296AC1014487494</a>	T06CLNT690	ECC6.0_ORDERS05	0000195063	AUSTRIA	B1.2007_PO		2010/06/29 18:10:57	2010/06/29 18:10
<a href="#">10062918155563874259AC101448B669</a>	T06CLNT690	ECC6.0_ORDERS05	0000195063	AUSTRIA	B1.2007_PO		2010/06/29 18:15:55	2010/06/29 18:15
<a href="#">10062918165163875098AC101448B4FF</a>	T06CLNT690	ECC6.0_DELVRY03	0081454857	AUSTRIA	B1.2007_DFT	320	2010/06/29 18:16:51	2010/06/29 18:16
<a href="#">10062918225163882110AC1014486358</a>	AUSTRIA	Z.B1.2007_PO	528	T06CLNT690	ECC6.0_ORDERS05	28!SBO_AT_528*2010900528	2010/06/29 18:22:51	2010/06/29 18:22
<a href="#">10062918231563883097AC1014483E9B</a>	T06CLNT690	ECC6.0_ORDERS05	0000195064	AUSTRIA	B1.2007_PO		2010/06/29 18:23:15	2010/06/29 18:23
<a href="#">10062918241663883942AC101448EEF3</a>	T06CLNT690	ECC6.0_ORDERS05	0000195064	AUSTRIA	B1.2007_PO		2010/06/29 18:24:16	2010/06/29 18:24
<a href="#">10062918244263884563AC1014488E5B</a>	T06CLNT690	ECC6.0_DELVRY03	0081454858	AUSTRIA	B1.2007_DFT	321	2010/06/29 18:24:42	2010/06/29 18:24
<a href="#">10062918463351201384AC1014483C21</a>	AUSTRIA	Z.B1.2007_PO	529	T06CLNT690	ECC6.0_ORDERS05	28!SBO_AT_529*2010900529	2010/06/29 18:46:33	2010/06/29 18:46
<a href="#">10062918465751202440AC101448B1E4</a>	T06CLNT690	ECC6.0_INVOIC02	0187034947	AUSTRIA	B1.2007_PINV	774	2010/06/29 18:46:57	2010/06/29 18:50
<a href="#">10062918470051202890AC101448438D</a>	T06CLNT690	ECC6.0_ORDERS05	0000195065	AUSTRIA	B1.2007_PO		2010/06/29 18:47:00	2010/06/29 18:47

## Verifica completezza dei dati

BIiSN verifica durante il percorso per ogni messaggio scambiato la completezza dei dati e se necessario li integra prelevandoli dal sender e/o dal receiver

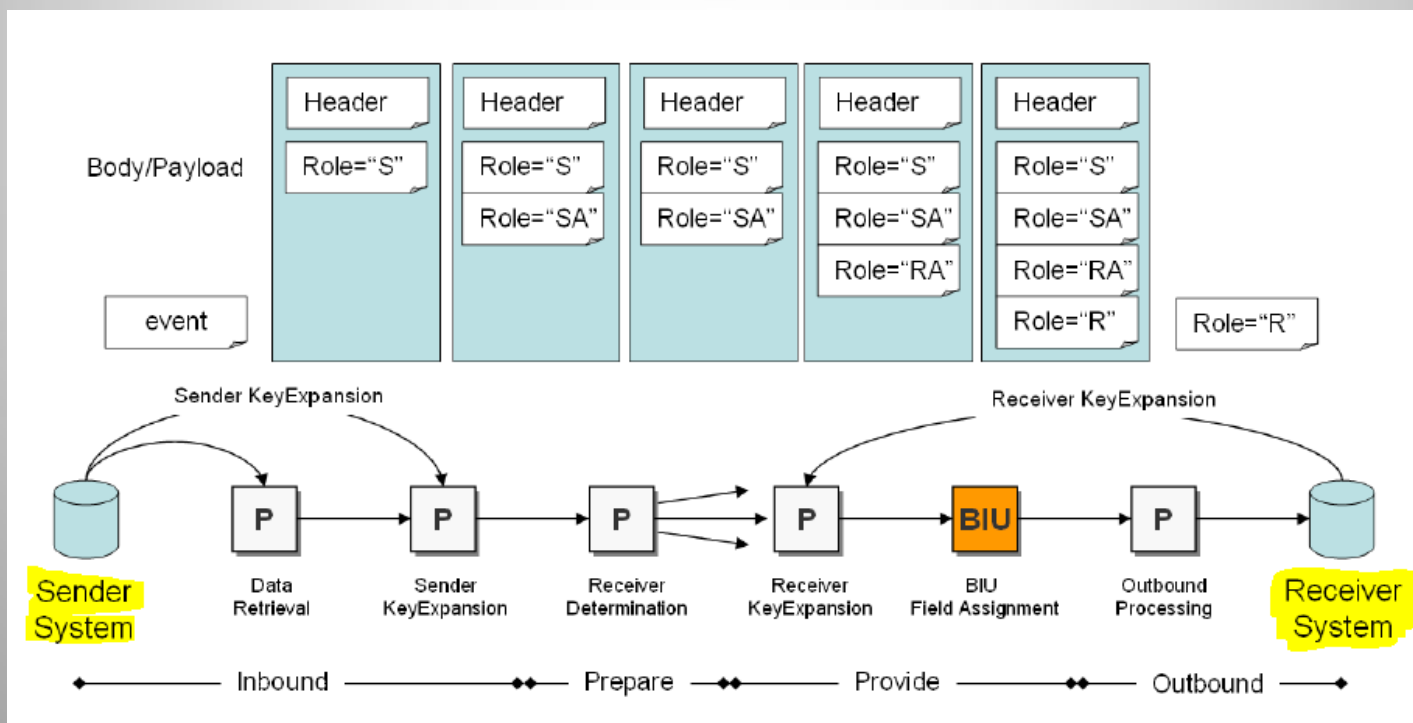

## Gestione errori

I messaggi in errore, possono essere nuovamente inviati dopo aver corretto il malfunzionamento.

Si possono impostare facilmente azioni automatiche di gestione degli errori, ad es. l'invio di una mail all'amministratore.

SAP Business One 2007 integration platform  
SAP Business One 2007 integration for SAP NetWeaver

Landscapes Initialization Business Processes Data Management Monitoring Tools

Semantical Error(s)		
Status	Receiver System	Error(s)
0	AUSTRIA	0
0	DANIMARCA	0
0	SVIZZERA	0
0	D06CLNT690	0
0	T06CLNT690	0

Queue Blocker		
Status	Receiver System	QB Summary
0	AUSTRIA	0
0	DANIMARCA	0
0	SVIZZERA	0
0	D06CLNT690	0
0	T06CLNT690	0

Technical Error(s)

SAP B1iSN Tools  
Version B1iSN2007.P11.3.46

Repository Tools Development Tools Configuration Tools Runtime Tools Action Handling Guide Miscellaneous

### Assignment and Configuration of B1iSN Error Actions

Selection Criteria [localhost:8080]

- List Daily Actions
- List Error Actions
- Assign Error Actions
  - Cfg email
  - Cfg DA: AutomaticResend
  - Cfg DA: MsgLog GC
  - Cfg DA: MsgLog Summary
  - Cfg DA: SendErrInboxStat.
  - Cfg EA: QueueBlockerAlert
  - Cfg EA: SendEmail

Outbound Phase

Task

Sender SysId

Receiver SysId

Sender ObjectType

Receiver ObjectType

ErrorAction1

ErrorAction2

ErrorAction3

ErrorAction4

ErrorAction5

ErrorAction6

ErrorAction7

ErrorAction8

Actions

BizStore document Selection -- Webpage Dialog

BizStore document Selection

Choose document

Select

- [ Choose value ]
- [ Choose value ]
- ErrAction\_DeleteInboundQueue
- ErrAction\_Mark4AutomaticRetrial
- ErrAction\_QueueBlockerAlert
- ErrAction\_SendEmail
- ErrAction\_SendErrorToB1R3RR
- ErrAction\_SendInfoToQBBlockerInbox
- ErrAction\_SendToErrorPath
- ErrAction\_VisitAndRetrial

List Save Modify Close Reset

*intecna*

innovazione miglioramento e tecnologie  
per l'azienda

**INTECNA scarl**

## **DOVE SIAMO E RIFERIMENTI**



**INTECNA scarl** -Viale Fulvio Testi ,11

20092 Cinisello Balsamo (MI)

Tel. +39 02 618 663 21 Fax. +39 02 618 667 10

e-mail [info@intecna.it](mailto:info@intecna.it) web [www.intecna.it](http://www.intecna.it)

**Ing. Peppino CUCCI**

Tel. +39 02 618 663 26 Mob. +39 335 546 9288

e-mail [cucci@intecna.it](mailto:cucci@intecna.it)

